

SERVICE MANUAL



FISHER

CR-5120

**Stereo Cassette Tape Deck
With DOLBY Noise Reducer
(EUROPE)**

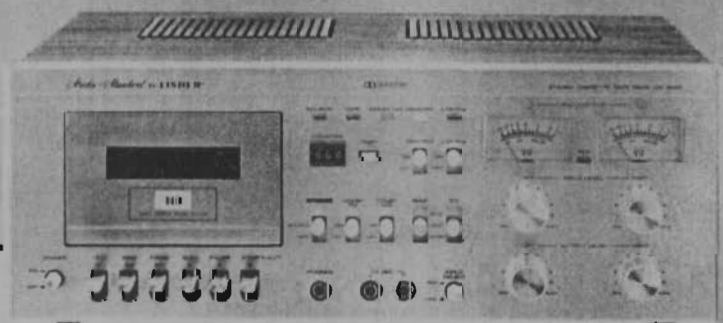

THE FIRST NAME IN HIGH FIDELITY

SPECIFICATIONS

Recording System	AC Bias	Distortion (3rd harmonic)	
Erasing System	AC Erasing	CHROME	2.5%
Reel Speed	1-7/8 ips. ±1%	NORMAL	1.5%
Fast Forward Time	100 sec. (C-60 cassette)	Terminal Impedance	
Reverse Wind Time	100 sec. (C-60 cassette)	MIC	10 k-ohm
Wow & Flutter	0.07% RMS	DIN INPUT	20 k-ohm
Frequency Response (Record/Playback)		DIN OUTPUT	2 k-ohm
CHROME	30 — 16,000 Hz	LINE IN	100 k-ohm
NORMAL	30 — 14,000 Hz	LINE OUT	2 k-ohm
Signal to Noise Ratio (Tape: CrO ₂)		Headphone	8 ohm
Without DOLBY	Better than 52 dB	Power Consumption	24 W
With DOLBY	Better than 62 dB	Power Source	AC 110/125/220V (50/60 Hz)
Headset Crosstalk			
Track to Track	Better than 70 dB		
Channel to Channel	Better than 40 dB		

—Specifications subject to change without notice.—

DISASSEMBLY

CABINET DISASSEMBLY

WOODEN CABINET ASSEMBLY REMOVAL

Unscrew the four screws (1 — 4) fastening the Wooden Cabinet assembly and remove the four washers. Remove the Wooden Cabinet assembly by lifting it.

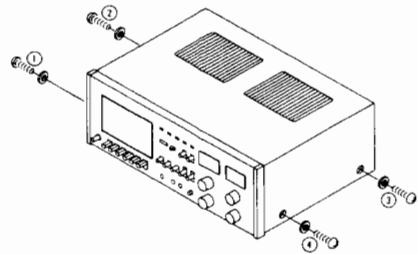

C. FRONT PANEL ASSEMBLY REMOVAL

1. Pull out the four knobs (A — D) from the unit.
2. Unscrew the two screws (12 — 13) fastening the lower side of the Front Panel assembly. Then, place the unit in an upright position.

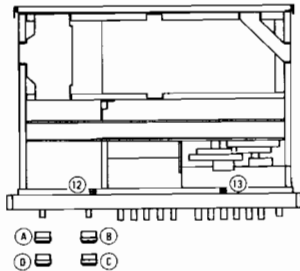

3. Unscrew the three screws (14 — 16) fastening the upper side of the Front Panel assembly. Pull out the connector (CN24) from the Pre-Amplifier P.C.B.

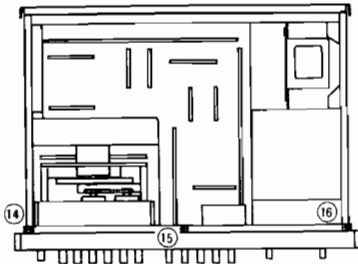

4. Remove the lead wires which connect the connector (CN24) with the Peak Indicator from the wire-clamps.
5. Remove the Front Panel assembly and the three spacers from the unit.

PANEL SHEET REMOVAL

Turn the unit upside down on a clean soft surface. Remove the Panel Sheet by unscrewing the seven screws (5 — 11) fastening it.

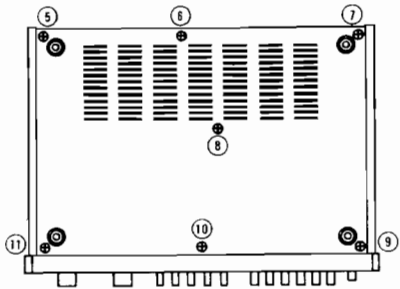

DISASSEMBLY (Continued)

D. BACK PANEL REMOVAL

1. Pull out the connector (CN27) connecting the RECEIVER DE-EMPHASIS Switch P.C.B. from the Switch P.C.B.
2. Pull out the connectors (CN17, CN34 and CN35) connecting the DIN socket from the Pre-Amplifier P.C.B.

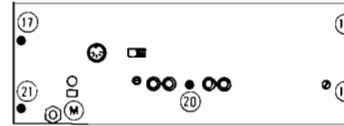

3. Loosen the nut (M) of the Bushing and remove the Back Panel from the unit by unscrewing the five screws (17 — 21) fastening it.

Reassemble the Cabinet in the reverse order.

PRE-AMPLIFIER P.C.B. ASSEMBLY REMOVAL

1. Follow the instructions for the Cabinet Disassembly.
2. Pull out the five knobs (E — I) of the switches attached to the Pre-Amplifier P.C.B. and unscrew the five screws (22 — 26) fastening the switches.
3. Pull out the connector (CN3) from the Power Supply P.C.B. and remove the lead wires from the wire clamps.
4. Pull out all connectors (CN12, 13, 14, 15, 16, 18, 19, 20, 21, 22, 23, 24, 28, 29, 36, 40, 41) and the RT Pin sockets (CN51, CN52 and CN53) which are necessary for the removal of the Pre-Amplifier P.C.B.
5. Unscrew the two screws (27 — 28) fastening the Record Lever Bracket and remove the Bracket.
6. Unscrew the five screws (29 — 33) and the three fiber washers (34 — 36) fastening the Pre-Amplifier P.C.B. and remove the P.C.B. from the unit.

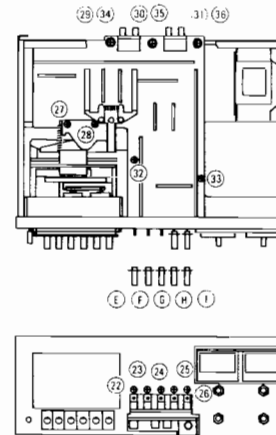

7. Reassemble in the reverse order.

JACK P.C.B. ASSEMBLY REMOVAL

1. Follow the instructions for the Cabinet Disassembly.
2. Turn the unit upside down and pull out the connectors (CN30, 31, 32, 33) from the Jack P.C.B.
3. Remove the spacer (L) and the nut (39) of the Headphone Jack.
4. To remove the P.C.B., unscrew the two screws (40 — 41) fastening the INPUT Selector.

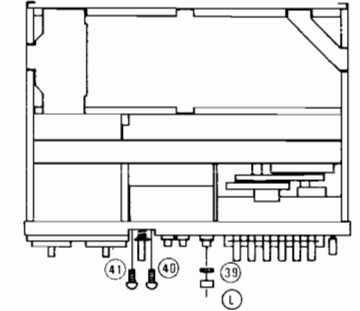

5. Reassemble in the reverse order.

SWITCH P.C.B. ASSEMBLY REMOVAL

(MEMORY & LIMITER SWITCHES)

1. Follow the instructions for the Cabinet Disassembly.
2. Pull out the two knobs (J — K) of the switches attached to the Switch P.C.B.
3. Pull out the connector (CN28) and the RT Pin socket (CN44) from the Pre-Amplifier P.C.B. and the Control Circuit P.C.B.
4. Pull out the two RT Pin sockets (CN42 and CN43) from the Switch P.C.B.
5. Unscrew the two screws (37 — 38) fastening the switches and remove the P.C.B. from the unit.

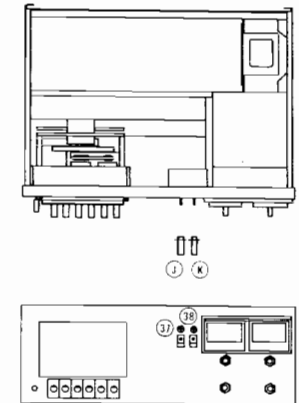

6. Reassemble in the reverse order.

DISASSEMBLY (Continued)

POWER P.C.B. ASSEMBLY REMOVAL

Follow the instructions for the Cabinet Disassembly.
Pull out the three connectors (CN1, CN2 and CN3) from the Power Supply P.C.B.
Unscrew the five screws (42 – 46) fastening the Power Supply P.C.B. and remove the P.C.B.

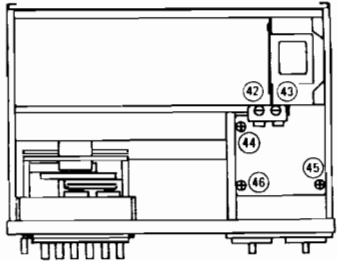

Reassemble in the reverse order.

VOLUME CONTROL P.C.B. ASSEMBLY REMOVAL

Follow the instructions for the Cabinet Disassembly.
Unsolder the lead wires which connect the P.C.B. with the Meters and the lead wires which connect P.C.B. with the meter illumination Lamps.
To remove the Volume Control P.C.B., remove the four nuts (48 – 51) fastening the Volume Controls.

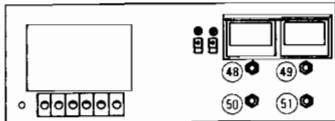

Reassemble in the reverse order.

CHASSIS REMOVAL

- Follow the instructions for the Cabinet Disassembly.
- Open the cassette compartment lid by pressing the EJECT button.
Then, remove the cassette compartment lid by unscrewing the two screws (52 – 53) fastening the lid.
- Unscrew the two screws (27 – 28) fastening the Record Lever Bracket and remove the Bracket.
- Pull out the connectors (CN1, 2, 14, 20, 21, 41) and the RT Pin sockets (CN45, CN49 and CN50) which are in nine places and remove the arranged lead wires.
- Remove the small Belt from the Counter.
- The Chassis is removed from the unit by unscrewing the four screws (54 – 57) fastening the Chassis.

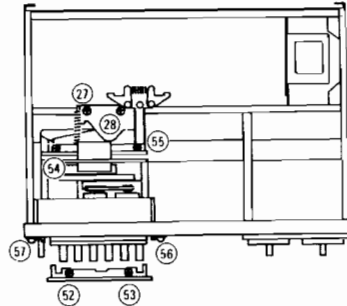

- Reassemble in the reverse order.

MECHANICAL ADJUSTMENT

GENERAL REMARKS

Before adjusting the mechanism of this unit, wipe the tape contacting surfaces clean as well as the contacting surfaces of the driving parts with a soft cloth soaked in alcohol.
Trouble may occur because of oil and grease stains.

REEL MOTOR SWITCH ADJUSTMENT

- The Reel Motor Switch should be "ON" the moment either one of the Pinch Rollers start rotating or immediately before the rotation, while the PLAY button is being pressed.
- If necessary, loosen the screw fastening the Switch Bracket and adjust the switch position by sliding the Bracket as illustrated.

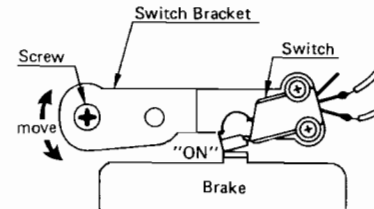

- After the adjustment, tighten the screw and check to see that the Reel Motor Switch is turned on by pressing the F. FWD and REW buttons.
- After checking, secure the screw with paint or glue.

PAUSE ADJUSTMENT

PAUSE TIMING ADJUSTMENT

- Press the PAUSE button slowly with the unit in the playback mode.
- The Take-up Reel should stop rotating:
 - At the SAME TIME while the second Pinch Roller stops rotating after it's separation from the Capstan.
 - IMMEDIATELY after the second Pinch Roller stops rotating.
- If necessary, adjust the clearance between the Pause Plate and the Pin of the Take-up Idler by bending the Pause Plate as illustrated.

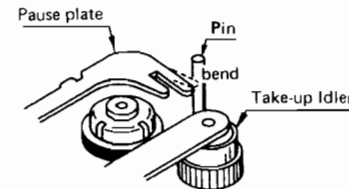

B. PAUSE SWITCH POSITION ADJUSTMENT

- Press the PAUSE button slowly with the unit in the playback mode.
- After the rotation of the Take-up Reel stops, the Reel Motor rotation should stop.
- If necessary, loosen the screw fastening the Switch Bracket with the PAUSE button down in the playback mode.
Then, slide the Switch Bracket as illustrated to the position where the Reel Motor stops.

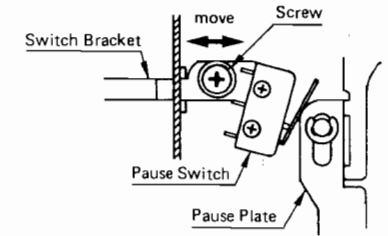

- After the adjustment, tighten the screw and secure it with paint or glue.

MUTING SWITCH ADJUSTMENT

- Loosen the screws fastening the Switch Bracket with the unit in the playback mode.
- Slide the Switch Bracket as illustrated until the Muting Switch is changed over.

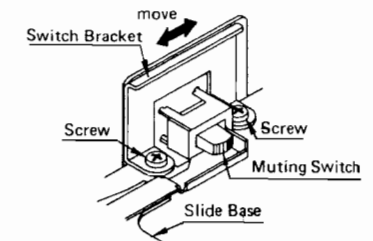

NOTE:

- Avoid moving the Slide Base by sliding the Switch Bracket forcibly.
- After the adjustment, tighten the screws and secure them with paint or glue.

MECHANICAL ADJUSTMENT (Continued)

TAPE RUNNING CONDITION ADJUSTMENT

Insert the Cassette Tape as described below into the unit and set the unit in the playback mode.
We recommend "TDK C-120SA" cassette tape for this adjustment.

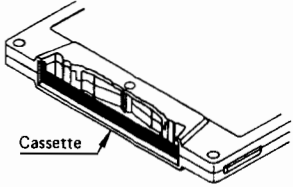

Pull the Pinch Roller of the supply side away from the Capstan as illustrated and check to see that the tape is curling with the Tape Guide of the Playback Head. Bring the Pinch Roller of the supply side into the Capstan as illustrated and check to see that the tape is curling with the Tape Guide of the Playback Head.

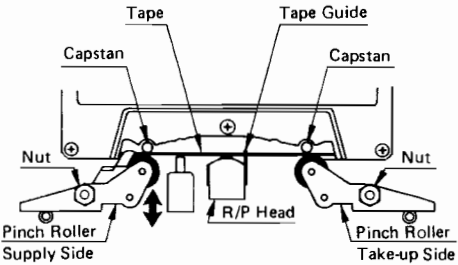

If necessary, adjust the Tape Running Condition by the following procedures:

- When the tape is curling at the upper section of the Tape Guide to the Playback Head, turn the adjusting nut of the Pinch Roller clockwise as illustrated until the curling is released.
- When the tape is curling at the lower section of the Tape Guide, turn the nut counter-clockwise as illustrated until the curling is released.

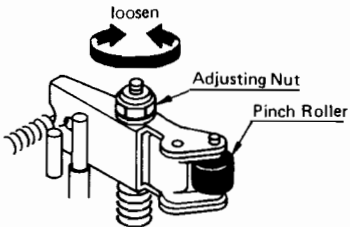

PINCH ROLLER HEIGHT ADJUSTMENT

If the Pinch Roller located on the take-up side is removed and replaced, adjust its height by the following procedures.

- Insert the cassette into the compartment and set the unit in the playback mode.
- Turn the adjusting nut until the clearance of about 0.5mm is obtained between the Pinch Roller Arm and the cassette as illustrated.

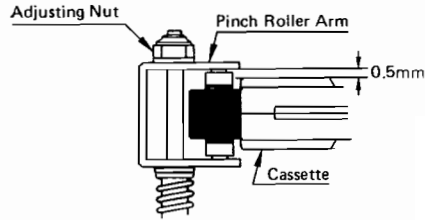

HALL IC MOUNTING

- Mount the Hall IC parallel to the Magnet Rotor as illustrated.
- Obtain the clearance of less than 1mm between the Hall IC and the Magnet Rotor as illustrated.

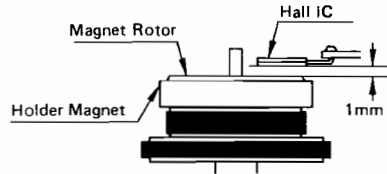

- Pull out the connector (CN6) from the Control Circuit P.C.B., and connect a constant-voltage regulator and an oscilloscope to the connector as illustrated.

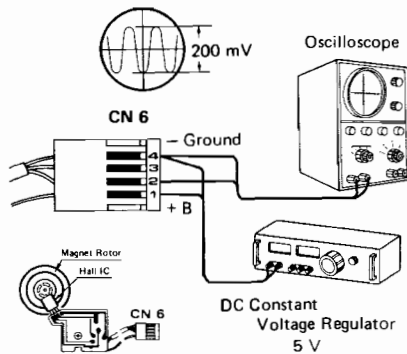

- Set the constant-voltage regulator to 5V, DC and slowly turn the Magnet Rotor.
- Check to see that the wave form is more than 200 mV peak-to-peak on the oscilloscope.

ELECTRICAL ADJUSTMENT

Prior to the Electrical Adjustments, set the unit and the measuring instruments as follows:

- INPUT SELECT Switch LINE
- MONITOR Switch TAPE
- DOLBY FM Switch OFF
- DOLBY NR Switch OFF
- BIAS Switch NORMAL
- EQUALIZER Switch NORMAL
- LIMITER Switch OFF
- OUTPUT LEVEL CONTROL MAXIMUM
- Audio Signal Generator Output Level 1 kHz, 0dB 1V
- Connect a 47k ohm dummy load to a VTVM and then, to a frequency counter.

NOTE:

Disconnect the dummy load from the VTVM when connecting the VTVM to a test point. The Electrical Adjustments should be performed in the order as described below.

TAPE SPEED ADJUSTMENT (MAIN MOTOR)

- Connect a frequency counter to the left or right channel LINE OUT as illustrated and play back a 3 kHz test tape (Example: TEAC MTT-111).

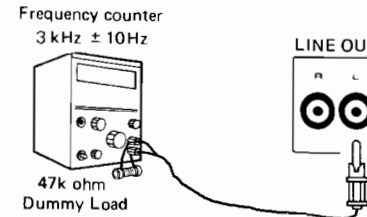

- Adjust the tape speed by turning the potentiometers (P2 and P3) in the Control Circuit P.C.B. indicated in the illustration to obtain 3,000 Hz \pm 10 Hz on the frequency counter.
 POTENTIOMETER (P2) For rough adjustment
 POTENTIOMETER (P3) For fine adjustment

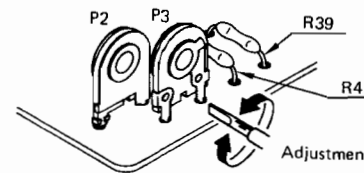

FAST-FORWARD & REWIND TIME ADJUSTMENT (REEL MOTOR)

- Insert a cassette tape (C-60) into the cassette compartment and measure the fast-forward and rewind time with the unit in each mode. Each time should be approximately 90 sec.
- If necessary, adjust the potentiometer (P1) in the Control Circuit P.C.B. to obtain the specified time.

PLAYBACK HEAD AZIMUTH ADJUSTMENT

- Connect a VTVM to the left channel LINE OUT as illustrated and play back a 12.5 kHz test tape (Example: TEAC MTT-116U).
- Turn the azimuth adjusting screw to obtain the maximum reading on the VTVM. (No.1 position)
- Disconnect the VTVM from the left channel LINE OUT and connect it to the right channel LINE OUT. Then, turn the adjusting screw to obtain the maximum reading on the VTVM. (No.2 position)

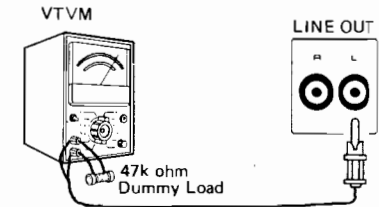

- Turn the adjusting screw to the center of the No.1 and No.2 positions as illustrated. (No.3 position)

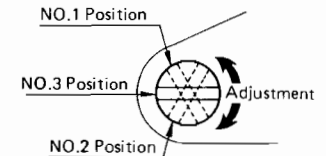
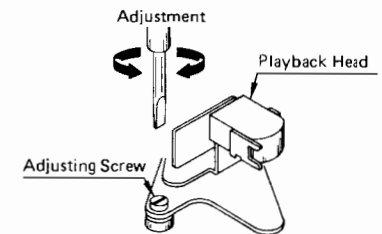

- Repeat the above described adjustment several times and adjust the azimuth correctly.
- After the adjustment, secure the adjusting screw with paint or glue.

RECORDING HEAD AZIMUTH ADJUSTMENT

Connect an audio signal generator and an attenuator to the left channel LINE IN and a VTVM to the left channel LINE OUT as illustrated. Then, turn the INPUT LEVEL controls to the maximum position.

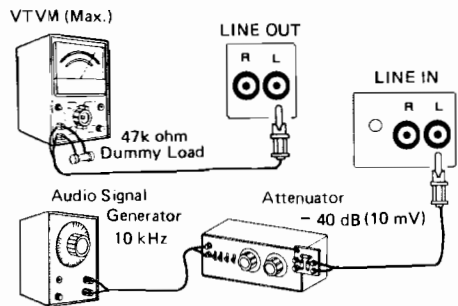

- While recording a 10 kHz signal on a normal tape (Example: BASF TP-18LHS) at -40 dB (10 mV) below 0 VU DOLBY mark, turn the azimuth adjusting screw to obtain the maximum reading on the VTVM. (No.1 position)
- Disconnect the measuring instruments from the left channel LINE IN and LINE OUT.
- Connect them to the right channel LINE IN and LINE OUT.
- Keeping the unit in the recording mode, turn the adjusting screw to obtain the maximum reading on the VTVM. (No.2 position)
- Turn the adjusting screw to the center of the No.1 and No.2 positions as illustrated. (No.3 position)

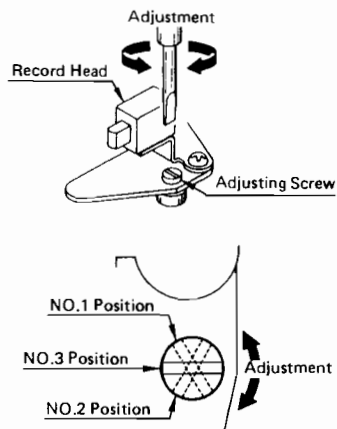

- Repeat the above described adjustment several times and adjust the azimuth correctly.
- After the adjustment, secure the adjusting screw with paint or glue.

PLAYBACK FREQUENCY RESPONSE ADJUSTMENT

LEFT CHANNEL

1. Connect a VTVM to the left channel LINE OUT as illustrated and play back a test tape (Example: TEAC MTT-116U) where the 315 Hz and 12.5 kHz signals are recorded.

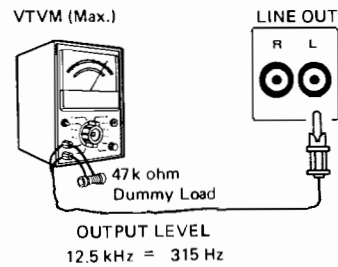

2. Adjust the potentiometer (P101) until the 12.5 kHz signal output becomes identical to the 315 Hz signal output or the deviation is ± 1 dB.

RIGHT CHANNEL

Adjust the potentiometer (P201) by using the same procedure.

PLAYBACK GAIN ADJUSTMENT

LEFT CHANNEL

1. Connect a VTVM to the test point (TP101) as illustrated and play back a test tape for the DOLBY level adjustment (Example: TEAC MTT-150).
2. Adjust the potentiometer (P102) to obtain the output of 580 mV on the VTVM.

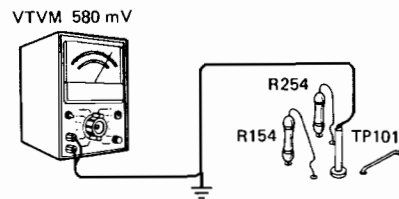

RIGHT CHANNEL

Connect the VTVM to the test point (TP201) and adjust the potentiometer (P202) by using same procedure.

OUTPUT LEVEL & METER ADJUSTMENT

LEFT CHANNEL

1. Connect an audio signal generator and an attenuator to the left channel LINE IN, and a VTVM to the test point (TP102) as illustrated.

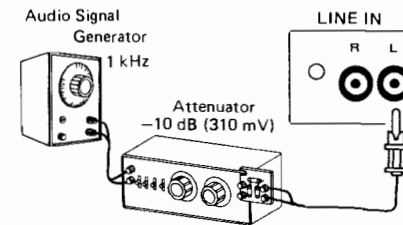

VTVM 580 mV

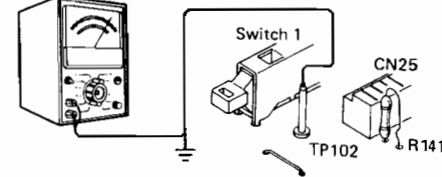

2. Set the MONITOR switch to SOURCE and feed a 1 kHz signal from the audio signal generator at -10 dB (310 mV) to the unit.
3. Turn the left channel INPUT LEVEL control (VR3) until the VTVM reading becomes the output of 580 mV.
4. Disconnect the VTVM from the test point (TP102) and connect it to the test point (TP101) as illustrated.

VTVM 580 mV

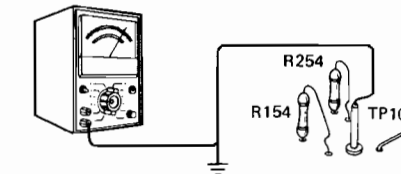

5. Adjust the potentiometer (P106) until the pointer of the left channel METER is positioned to +3VU as illustrated.

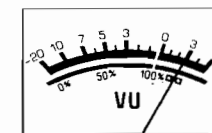

RIGHT CHANNEL

Connect the audio signal generator and the attenuator to the right channel LINE IN, and the VTVM to the test points (TP202 and TP201) alternately. Then, adjust the right channel INPUT LEVEL control (VR4) and the potentiometers (P206 and P203) by following the same procedure as for the left channel.

RECORDING BIAS ADJUSTMENT

LEFT CHANNEL

1. Connect an audio signal generator and an attenuator to the left channel LINE IN and a VTVM to the left channel LINE OUT as illustrated.

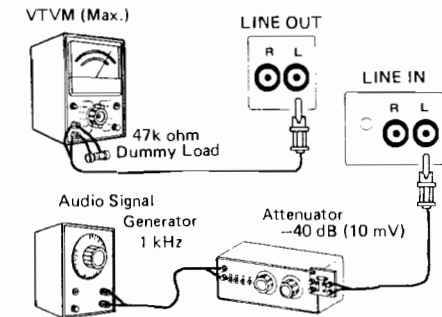

2. Set the BIAS and EQUALIZER switches to CrO2. Then, insert a chromium dioxide tape (Example: BASF TP-18CrO2) into the cassette compartment and set the unit in the recording mode.
3. Feed a 1 kHz signal from the audio signal generator at -40 dB (10 mV) to the unit and read the output level on the VTVM.
4. Set the signal generator at 14 kHz and adjust the potentiometer (P104), so that the output level becomes -1 dB ± 1 dB compared with the 1 kHz signal output level.
5. Repeat the above adjustment several times and until an optimum is reached.

RIGHT CHANNEL

Adjust the potentiometer (P204) by using the same procedure.

ELECTRICAL ADJUSTMENT (Continued)

RECORDING GAIN ADJUSTMENT

LEFT CHANNEL

Connect an audio signal generator and an attenuator to the left channel LINE IN and a VTVM to the test point (TP102) as illustrated.

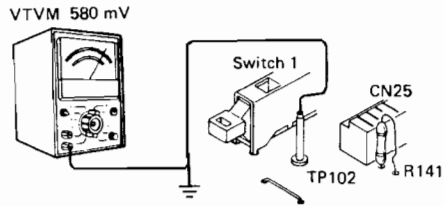
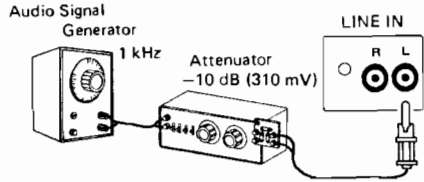

Set the MONITOR switch to SOURCE and feed a 1 kHz signal at -10 dB (310 mV) to the unit.

Adjust the left channel INPUT LEVEL control (VR3) to for a 580 mV on the VTVM.

Disconnect the VTVM from the test point (TP102) and connect it to the test point (TP101).

Then, set the BIAS and EQUALIZER switches to CrO2 and the MONITOR switch to TAPE. Adjust the potentiometer (P105) to obtain $580 \text{ mV} \pm 0.2 \text{ dB}$ (10 mV) on the VTVM while the signal is being recorded on a chromium dioxide tape (Example: BASF TP-18CrO2).

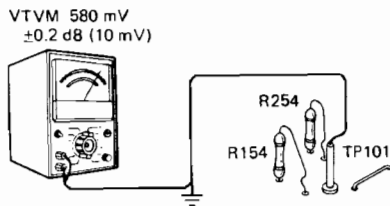

- Repeat the above adjustment several times until an optimum is reached.

RIGHT CHANNEL

Connect an audio signal generator and an attenuator to the right channel LINE IN and a VTVM to the test points (TP202 and TP201) alternately.

Then, adjust the INPUT LEVEL control (VR4) and the potentiometer (P205) by following the same procedure as for the left channel.

MEMO

PARTS LIST

Ref. No.	Part No.	Description	Q'ty	Ref. No.	Part No.	Description	Q'ty
MECHANISM				MECHANISM			
141 2 4539	01400	Washer	1	101 3 1303	00511	Screw, Pan Hd. +M3.0x5	1
112 3 1302	50040	E Ring	1	110 3 1104	00011	Small Round Washer M4.0	1
141 2 8519	59500	Spring, Wind Idler	1	110 3 9451	00053	Washer M4.5x10.0x0.5	2
141 2 7319	26400	Plate, Wind	1	141 0 3519	09201	Ejector Bracket Assy	1
141 2 8519	59700	Spring, Wind Plate	1	101 3 1303	00511	Screw, Pan Hd. +M3.0x5	2
112 3 1303	00040	E Ring	2	141 2 3519	27300	Plate Fix Chassis	1
141 2 7319	26300	Play Plate	1	141 0 3519	09200	Ejector Bracket Assy	1
141 2 8519	59800	Spring, Play Plate	1	101 3 1303	00511	Screw, Pan Hd. +M3.0x5	2
112 3 1303	00040	E Ring	2	141 2 3519	27301	Plate Fix Chassis	1
112 3 1302	50040	E Ring	2	141 0 3519	09300	Bracket Lever Link Assy	1
141 0 7419	15200	Pause Lever Assy	1	101 3 1303	00411	Screw, Pan Hd. +M3.0x4	2
112 3 1301	50040	E Ring	1	141 0 3519	09301	Bracket Lever Link Assy	1
141 0 7419	15300	Pause Lever Assy	1	101 3 1303	00411	Screw, Pan Hd. +M3.0x4	2
112 3 1301	50040	E Ring	1	141 0 3519	10000	Ejector Assy	1
112 3 1303	00040	E Ring	2	141 2 7529	50700	Pin Guide Lever Link	2
141 2 7319	26500	Plate, Stop Eject	1	141 2 7529	50600	Pin, Holder Cassette	2
141 2 8519	60000	Spring, Plate	1	141 2 4469	20000	Push, Cassette	1
141 0 7319	14300	Pause Plate Assy	1	112 3 2302	00086	Push, Nut-E	2
112 3 1303	00040	E Ring	2	141 2 8539	23800	Spring, Cassette	4
141 2 8519	64100	Spring, Pause Lever	1	141 2 8219	21000	Cassette Guide	1
141 2 5369	02700	Switch Bracket	1	141 2 8219	21100	Cassette Guide	1
101 3 1302	01011	Screw, Pan Hd. +M2.0x10	2	101 3 1302	60411	Screw, Pan Hd. +M2.6x4	4
101 3 1303	00511	Screw, Pan Hd. +M3.0x5	1	141 2 7529	58200	Spacer	2
141 2 7529	50300	Spacer	1	101 3 1702	00311	Screw, Bind Hd. +M2.0x3	2
101 3 1302	00411	Screw, Pan Hd. +M2.0x4	1	141 0 3519	10300	Bracket Assy	1
141 0 3519	09000	Rewind Switch Bracket Assy	1	141 2 3519	26600	Cassette Adjust	1
112 3 1302	50040	E Ring	1	101 3 1302	60311	Screw, Pan Hd. +M2.6x3	1
101 3 1302	01611	Screw, Pan Hd. +M2.0x16	2	101 3 1303	00511	Screw, Pan Hd. +M3.0x5	1
101 3 1303	00411	Screw, Pan Hd. +M3.0x4	2	141 0 3519	10200	Lever Kick Out Assy	1
141 2 8519	04800	Spring, Rewind Lever	1	202 5 9410	010101	Diode, 10D-1	1
141 2 3519	28800	Rewind Switch Bracket	1	4 2319	71330	Micro Switch (Pause Switch)	1
141 0 3519	09100	Contact Lever Assy	1	141 2 8519	33100	Spring, Roller Arm Lever	1
101 3 1303	00411	Screw, Pan Hd. +M3.0x4	2	4 2319	71330	Micro Switch (Rewind Switch)	1
141 0 5219	03200	Flywheel Assy	1	4 2319	71330	Micro Switch (Rewind Switch)	1
141 2 4539	01500	Washer	4	141 0 6139	00800	Function Button Assy	1
141 2 4539	13400	Washer, Oil Cut	1	4 2319	72350	Push Push Switch (Power Switch)	1
141 0 5219	03201	Flywheel Assy	1	4 2439	70352	Power Cord	1
141 2 4539	01500	Washer	1	4 2519	72350	Power Transformer	1
141 2 4539	13400	Washer, Oil Cut	1	4 5119	70400	Indicator	1
141 0 3169	02900	Bracket Assy	1	4 5119	70400	Indicator	1
101 3 1303	00411	Screw, Pan Hd. +M3.0x4	1	111 2 7210	10400	Wire Band HP	3
141 2 4469	02500	Pad, Capstan	2	141 0 3159	00300	Back Frame Assy	1
141 0 3789	00800	Motor Bracket Assy	1	141 0 3169	03100	Bracket Assy	1
141 2 4469	19900	Adjust Screw	2	141 0 7319	16300	Slide Switch Assy	1
141 0 8429	01000	Connecting Rod Assy	1	141 2 1149	16401	Panel Chassis	1
112 3 1303	00040	E Ring	2	141 2 1559	01200	Knob	1
141 2 3519	25600	Motor Bracket Main	1	141 2 3159	00900	Bracket	1
141 2 4459	08201	Motor Cushion	4	141 2 3159	01000	Back Frame	1
141 2 3789	01400	Motor Spacer	4	141 2 3159	01101	Frame	1
141 2 4579	00100	Washer	4	141 2 3159	01103	Frame	1
101 3 1302	61011	Screw, Pan Hd. +M2.6x10	4	141 2 3519	34000	Power Switch Bracket	1
101 3 1302	60611	Screw, Pan Hd. +M2.6x6	2	141 2 3719	03700	Transformer Bracket	1
101 3 1802	60811	Screw, Truss Hd. +M2.6x8	2	141 2 3739	03400	Meter Holder	1
101 3 1303	00611	Screw, Pan Hd. +M3.0x6	2	141 2 3739	03500	Meter Holder	1
141 2 3799	02700	Motor Pulley	1	141 2 3769	05100	Spacer, Jack	1
101 3 1302	60411	Screw, Pan Hd. +M2.6x4	3	141 2 3769	05101	Spacer, Jack	2
141 2 5649	09200	Belt	1	141 2 3899	08200	Bushing	1
141 2 3519	26400	Bracket, Muting Switch	1	141 2 4359	06501	Insulator	1
101 3 1303	00411	Screw, Pan Hd. +M3.0x4	4	141 2 4359	18900	Switch Cover Upper	1
101 3 1303	00511	Screw, Pan Hd. +M3.0x5	2	141 2 4359	19000	Switch Cover Lower	1
141 2 4539	01900	Washer	1	141 2 4729	05200	Clamp Wire	6
141 0 3519	09700	Pulley Bracket Assy	1	141 2 4729	05300	Band Wire	3
101 3 1303	00411	Screw, Pan Hd. +M3.0x4	2	141 2 7529	50300	Spacer	1
141 2 6519	21500	Pulley, Counter	1	141 2 8119	03800	Counter (Counter Switch)	1
141 2 4539	01400	Washer	2	141 0 8459	00700	Record Bracket Assy	1
141 2 5649	08900	Belt	1	103 3 1303	00811	Screw, Pan Hd. Tapping-2 +M3.0x8	2
141 2 5649	09000	Belt	1	112 3 1303	00040	E Ring	1
112 3 1301	50040	E Ring	1	141 2 8519	03100	Spring, Latch Plate	1
141 2 7419	39400	Shut-off Lever	1	141 0 8459	00800	Lever Assy	1
101 3 1303	01011	Screw, Pan Hd. +M3.0x10	1	112 3 1303	00040	E Ring	1
101 3 1303	00411	Screw, Pan Hd. +M3.0x4	2	141 2 8519	16700	Spring, Slide Plate Eject	1
141 2 3519	27400	Bracket, Hall IC P.C.B.	1	4 2239	70280	Capacitor (0.01 μF)	1
106 3 1103	00111	Nut-1	1	4 6129	70212	Lamp (Source)	1

PARTS LIST

Ref. No.	Part No.	Description	Q'ty	
MECHANISM				
PL2	141 2 3739	00500	Indicator Holder	7
PL3	4 6129	70212	Lamp (Tape)	1
PL4	4 6129	70212	Lamp (DOLBY NR)	1
PL5	4 6129	70212	Lamp (Memory)	1
PL6	4 6129	70212	Lamp (Limiter)	1
PL7	4 6129	70212	Lamp (Record)	1
PL8	4 6129	70212	Lamp (Meter)	1
	4 6129	70212	Lamp (Meter)	1
	143 3 1303	00611	Screw, Pan Hd. Tapping-2 +M3.0x6	27
	103 3 1302	60611	Screw, Pan Hd. Tapping-2 +M2.6x6	3
	101 3 1303	00511	Screw, Pan Hd. +M3.0x5	2
	101 3 1303	00411	Screw, Pan Hd. +M3.0x4	2
	131 3 1304	00611	Screw, Pan Hd. C SW +M4.0x6	4
	110 3 1204	00011	Finished Washer	2
	131 3 1304	00611	Screw, Pan Hd. C SW +M4.0x6	2
	112 3 1302	50040	E Ring	1
	141 2 4219	06300	Screw	1
	112 3 1303	00040	E Ring	1
	101 3 1303	00511	Screw, Pan Hd. +M3.0x5	2
	143 3 1303	00611	Screw, Pan Hd. Tapping-2 +M3.0x6	4
	141 2 4539	03200	Fiber Washer	3
	143 3 1303	00611	Screw, Pan Hd. Tapping-2 +M3.0x6	5
	143 3 1303	00811	Screw, Pan Hd. Tapping-2 +M3.0x8	2
	141 2 3169	09501	Bracket	1
	143 3 1303	00611	Screw, Pan Hd. Tapping-2 +M3.0x6	4
	141 2 4359	18100	Insulator	2
	101 3 1303	00511	Screw, Pan Hd. +M3.0x5	1
S20	4 2319	72310	Rotor Switch (Voltage Selector)	1
	101 3 1303	01011	Screw, Pan Hd. +M3.0x10	2
	141 2 4359	17900	Switch Cover	1
	4 2379	70560	Terminal	1
	101 3 1303	01611	Screw, Pan Hd. +M3.0x16	1
	141 2 4359	16600	Insulator	1

NOTES: 1. Parts order must contain Model Number, Part Number and Description.
2. Ordering quantity of screws and resistors must be multiple of 10 pcs.

EXPLODED VIEW

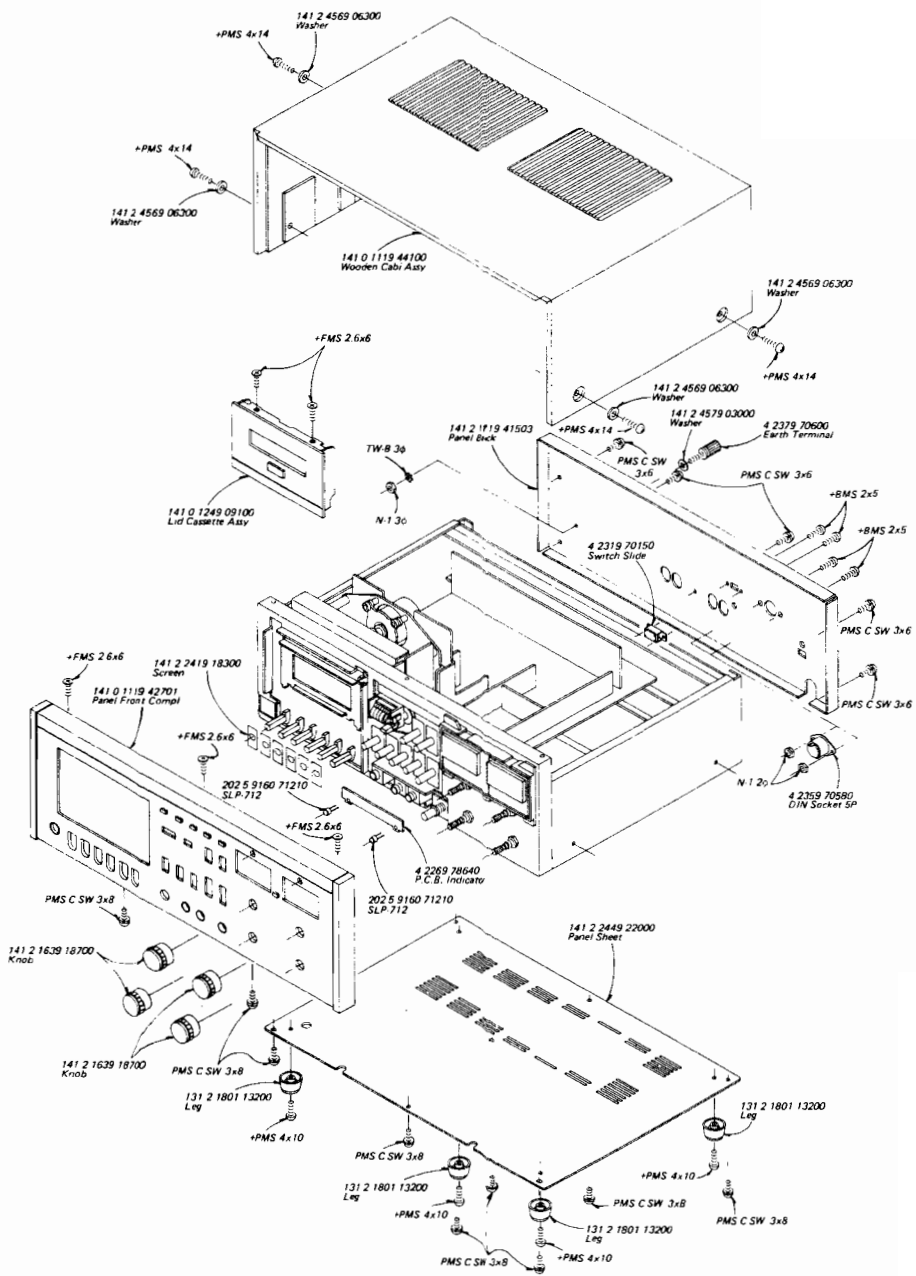

EXPLODED VIEW

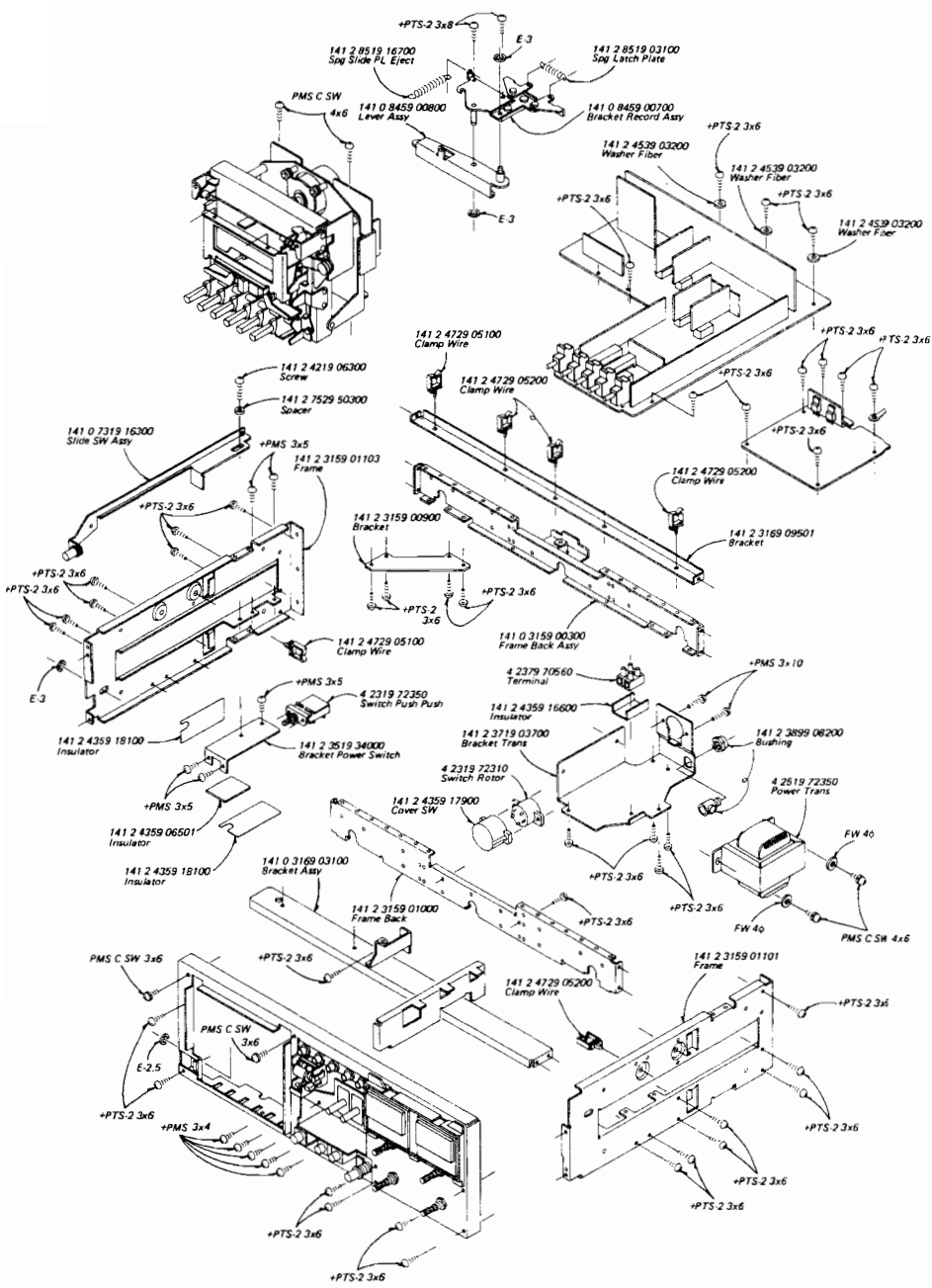

EXPLODED VIEW

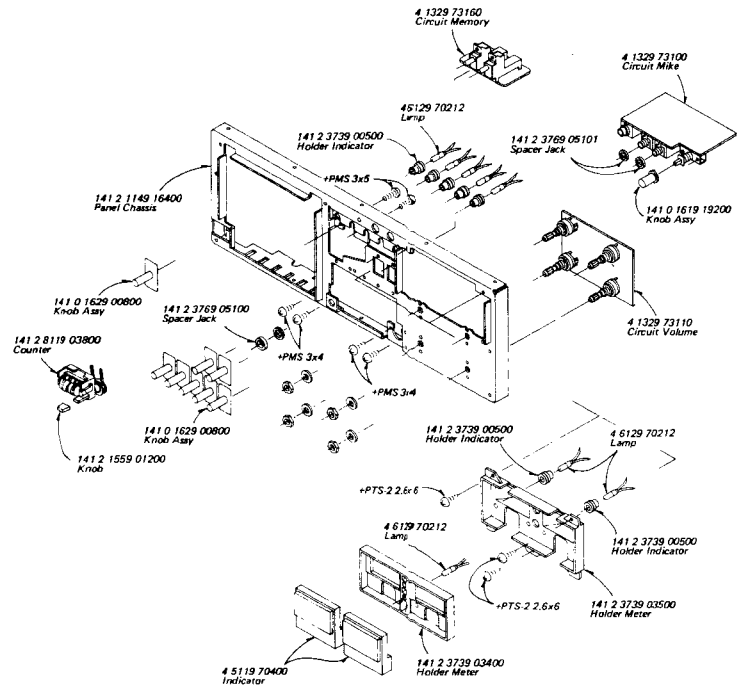

EXPLODED VIEW

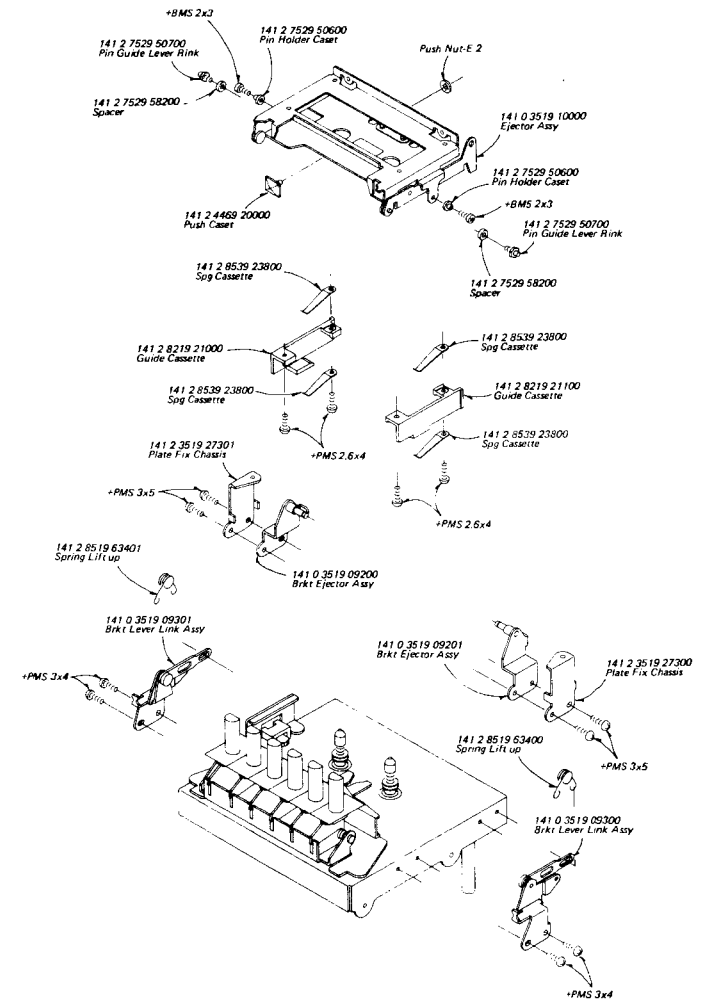

EXPLODED VIEW

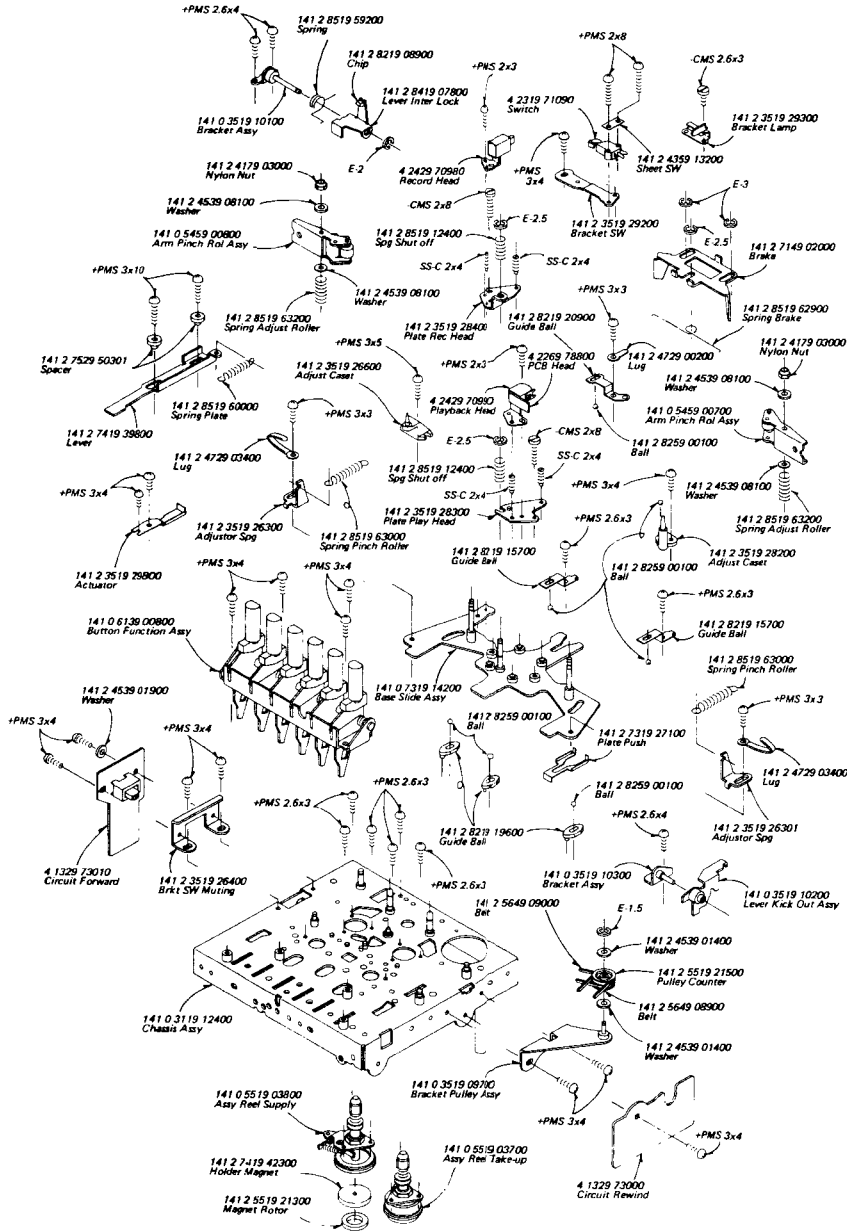

EXPLODED VIEW

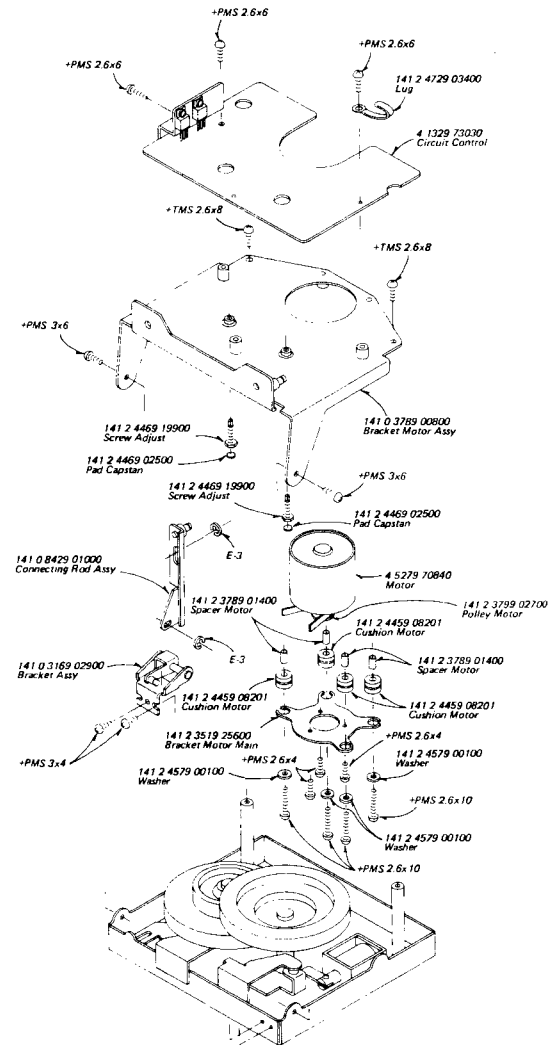

EXPLODED VIEW

PRE-AMP UNIT P.C.BOARD

PRE-AMP UNIT SCHEMATIC DIAGRAM

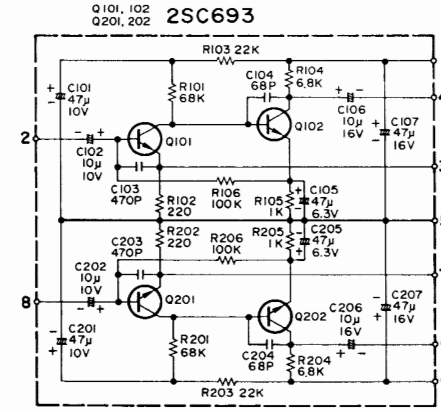

PRE-AMP UNIT P.C.B. (Top View)

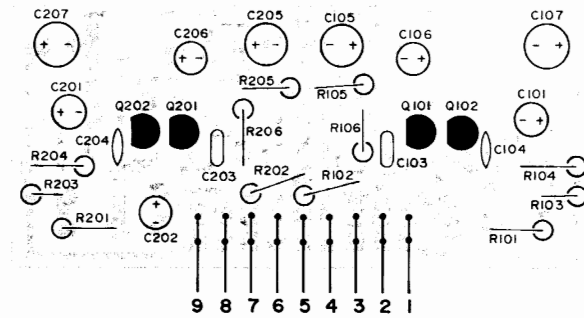

PRE-AMP UNIT P.C.B. (Bottom View)

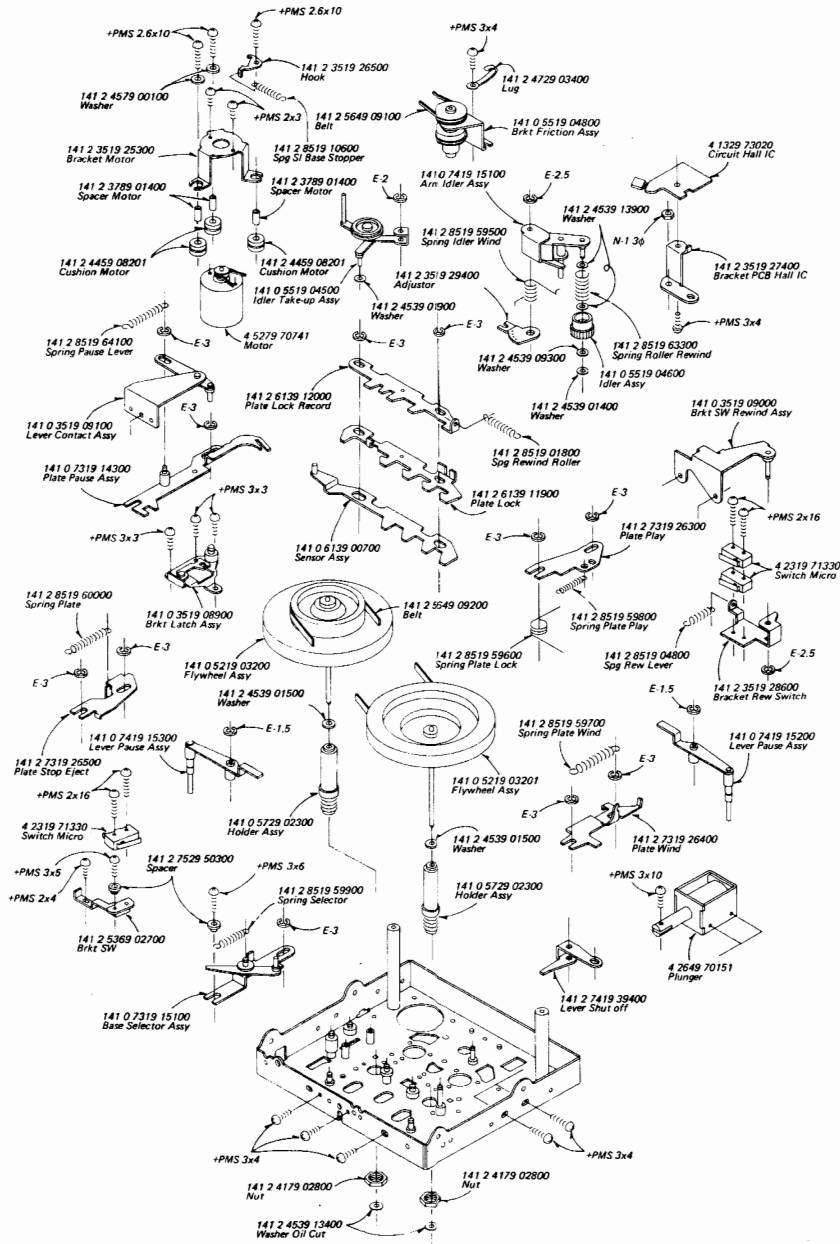
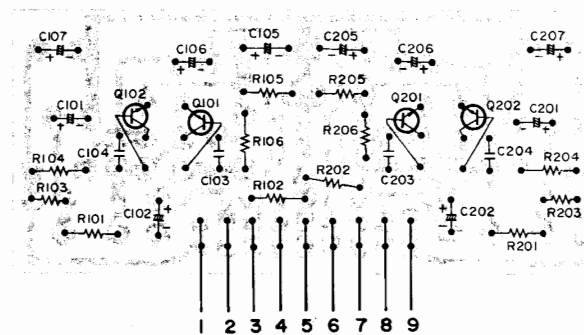

LINE AMP UNIT P.C.BOARD

LINE AMP UNIT SCHEMATIC DIAGRAM

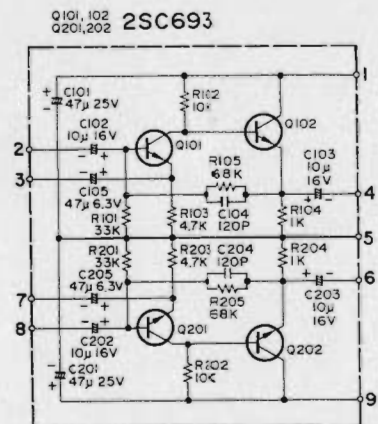

LINE AMP UNIT P.C.B. (Top View)

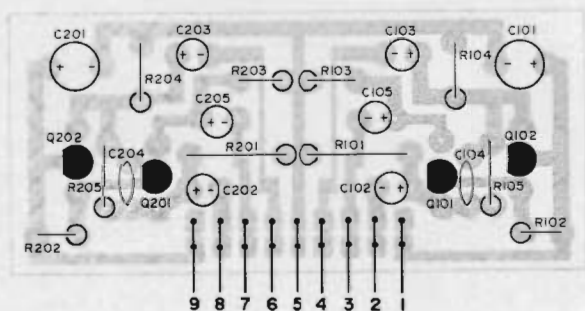

LINE AMP UNIT P.C.B. (Bottom View)

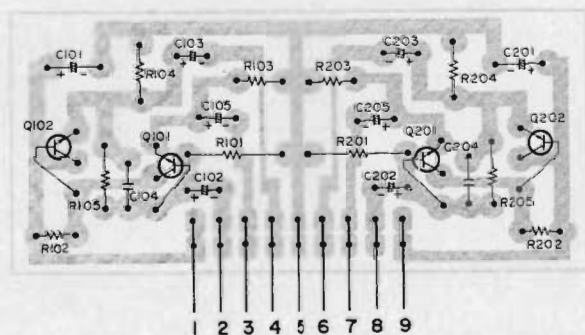

RECORD AMP UNIT P.C.BOARD

RECORD AMP UNIT SCHEMATIC DIAGRAM

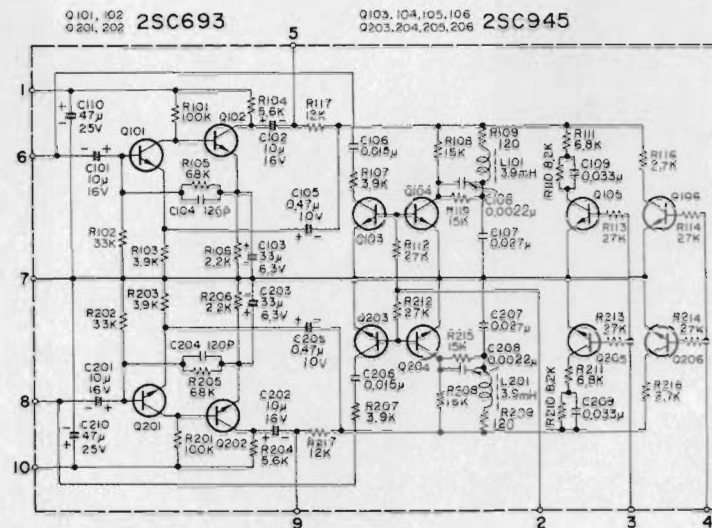

RECORD AMP UNIT P.C.B. (Top View)

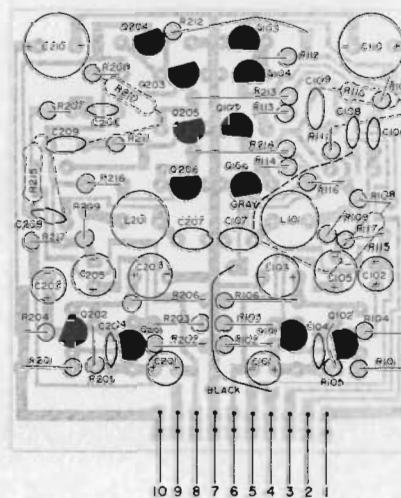

RECORD AMP UNIT P.C.B. (Bottom View)

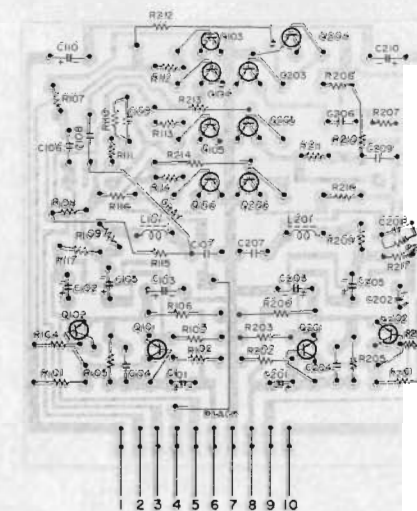

DOLBY NR UNIT P.C.BOARD

DOLBY NR UNIT SCHEMATIC DIAGRAM (RECORD)

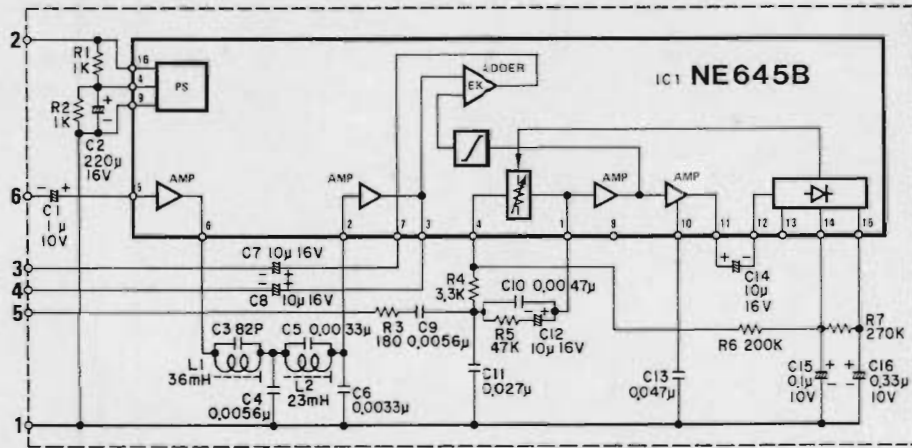

DOLBY NR UNIT P.C.B. TOP VIEW (RECORD)

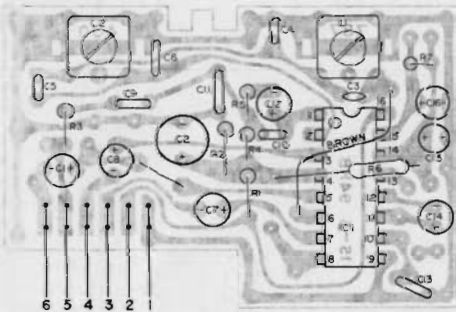

DOLBY NR UNIT P.C.B. BOTTOM VIEW (RECORD)

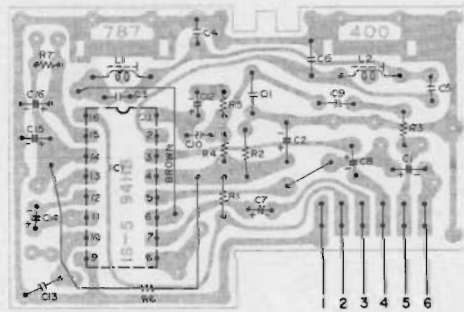

CONTROL CIRCUIT P.C. BOARD

CONTROL CIRCUIT (Top View)

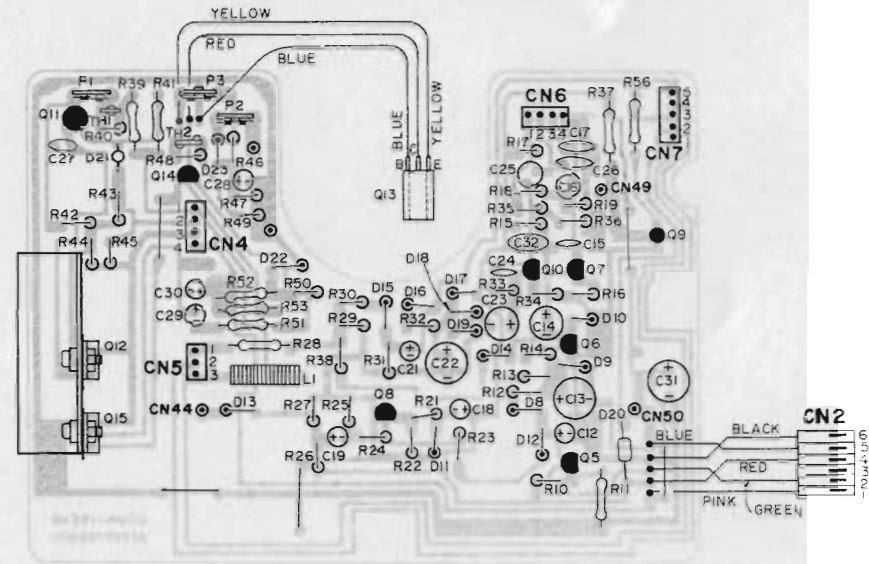

CONTROL CIRCUIT (Bottom View)

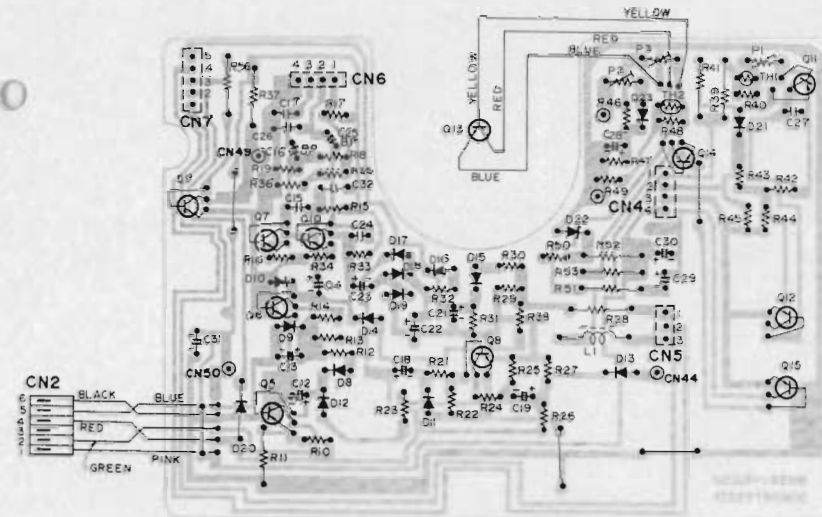

POWER SUPPLY P.C. BOARD

POWER SUPPLY P.C.B. (Top View)

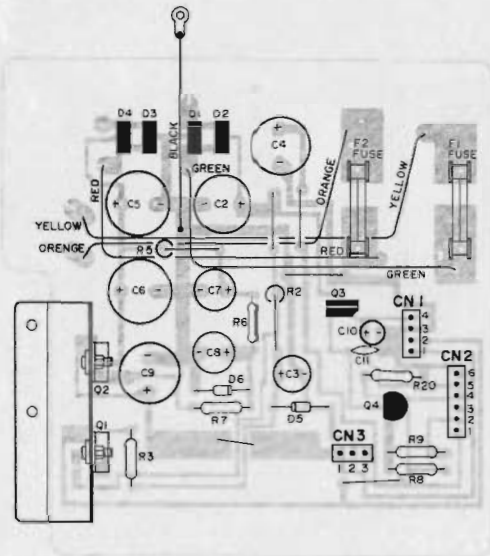

POWER SUPPLY P.C.B. (Bottom View)

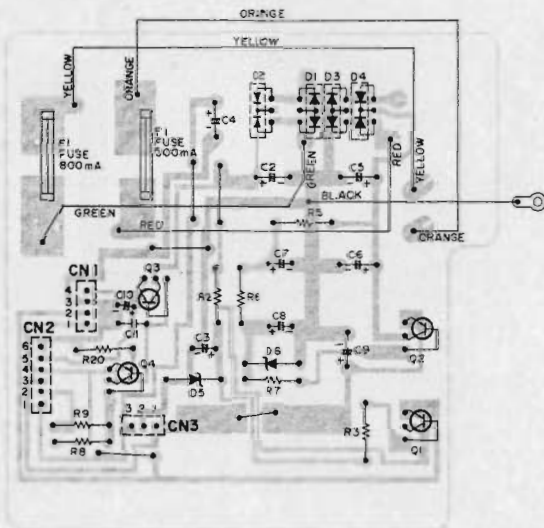

VOLUME CONTROL P.C. BOARD

VOLUME CONTROL P.C.B. (Top View)

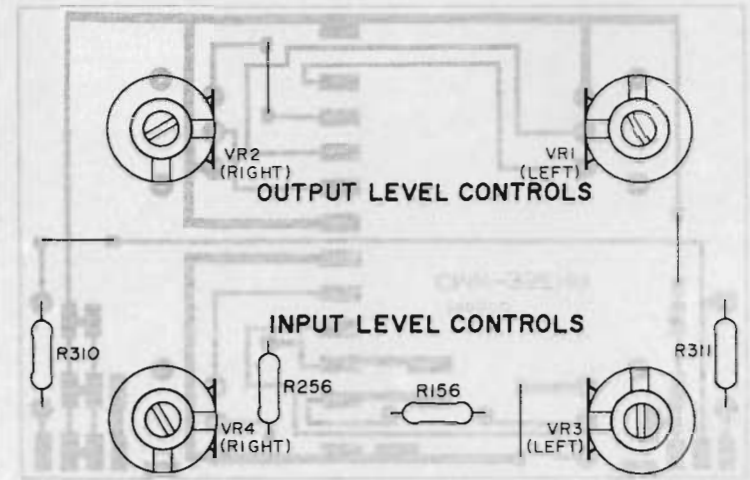

VOLUME CONTROL P.C.B. (Bottom View)

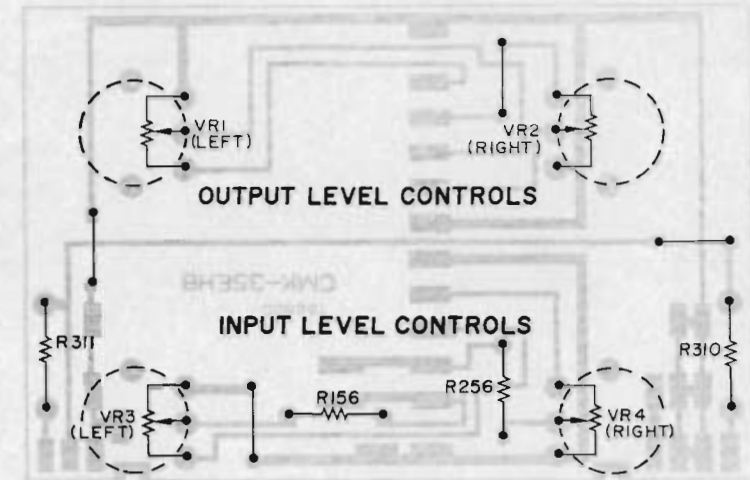

JACK P.C. BOARD

JACK P.C.B. (Top View)

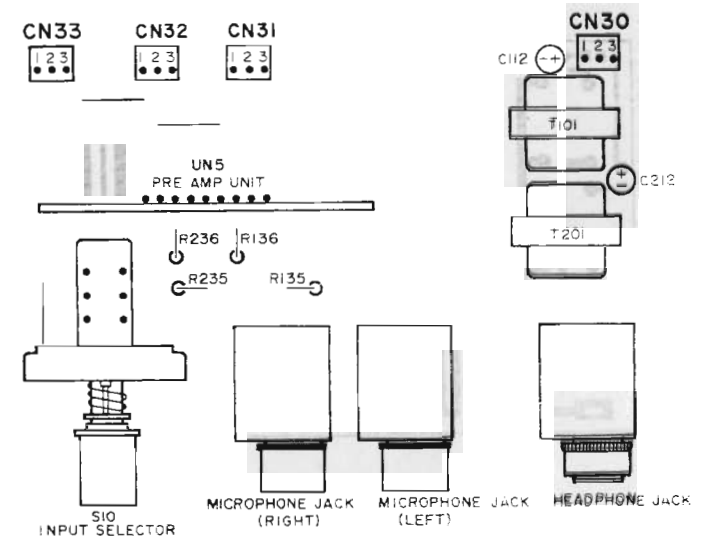

JACK P.C.B. (Bottom View)

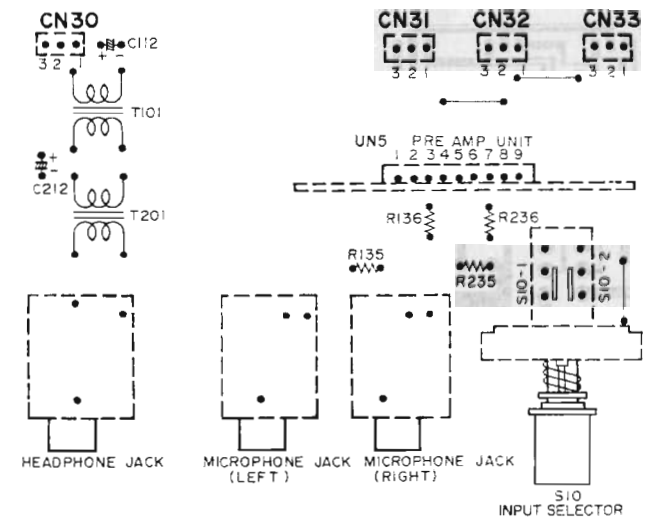

AMPLIFIER BASE P.C.BOARD (TOP VIEW)

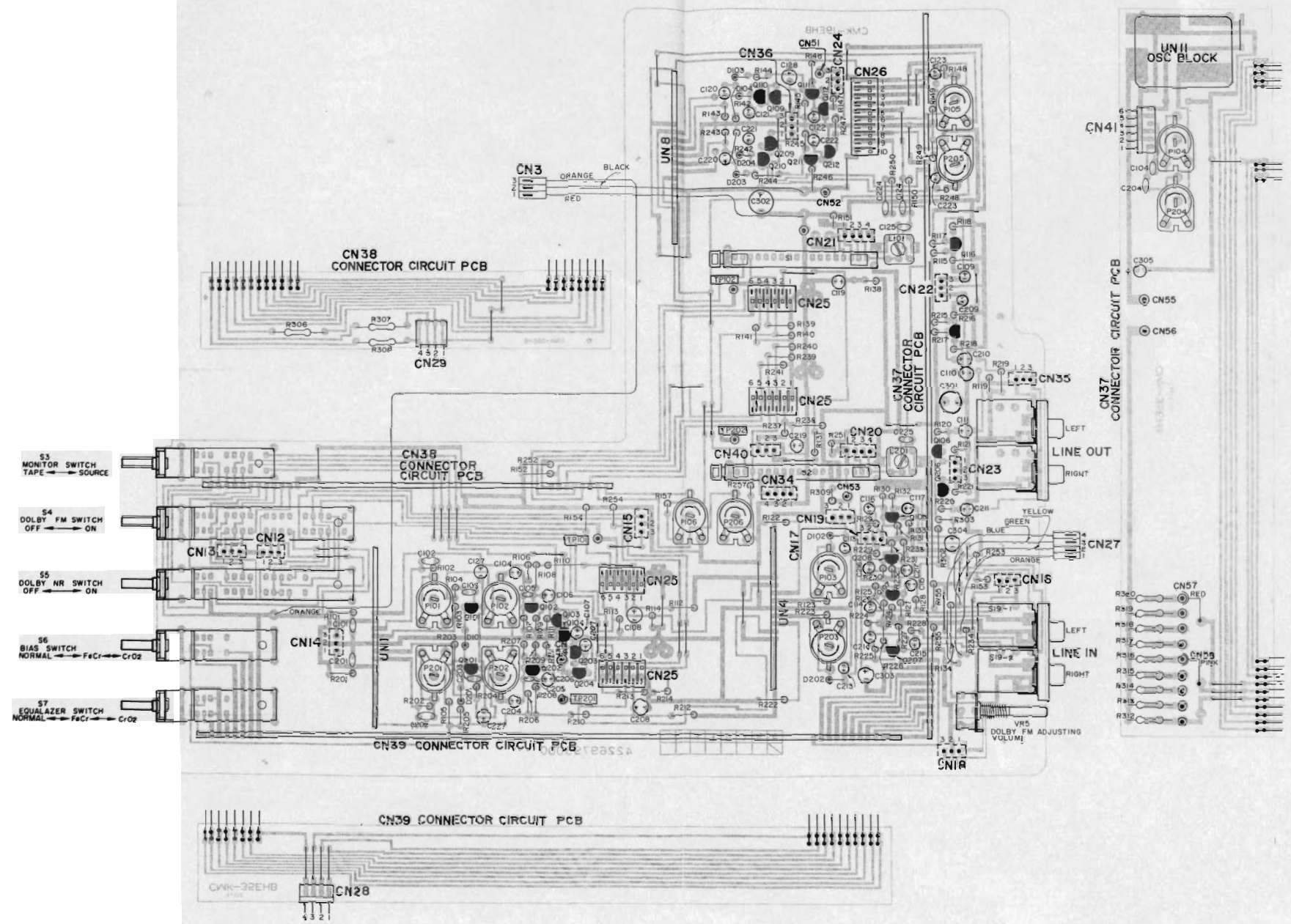

AMPLIFIER BASE P.C.BOARD (BOTTOM VIEW)

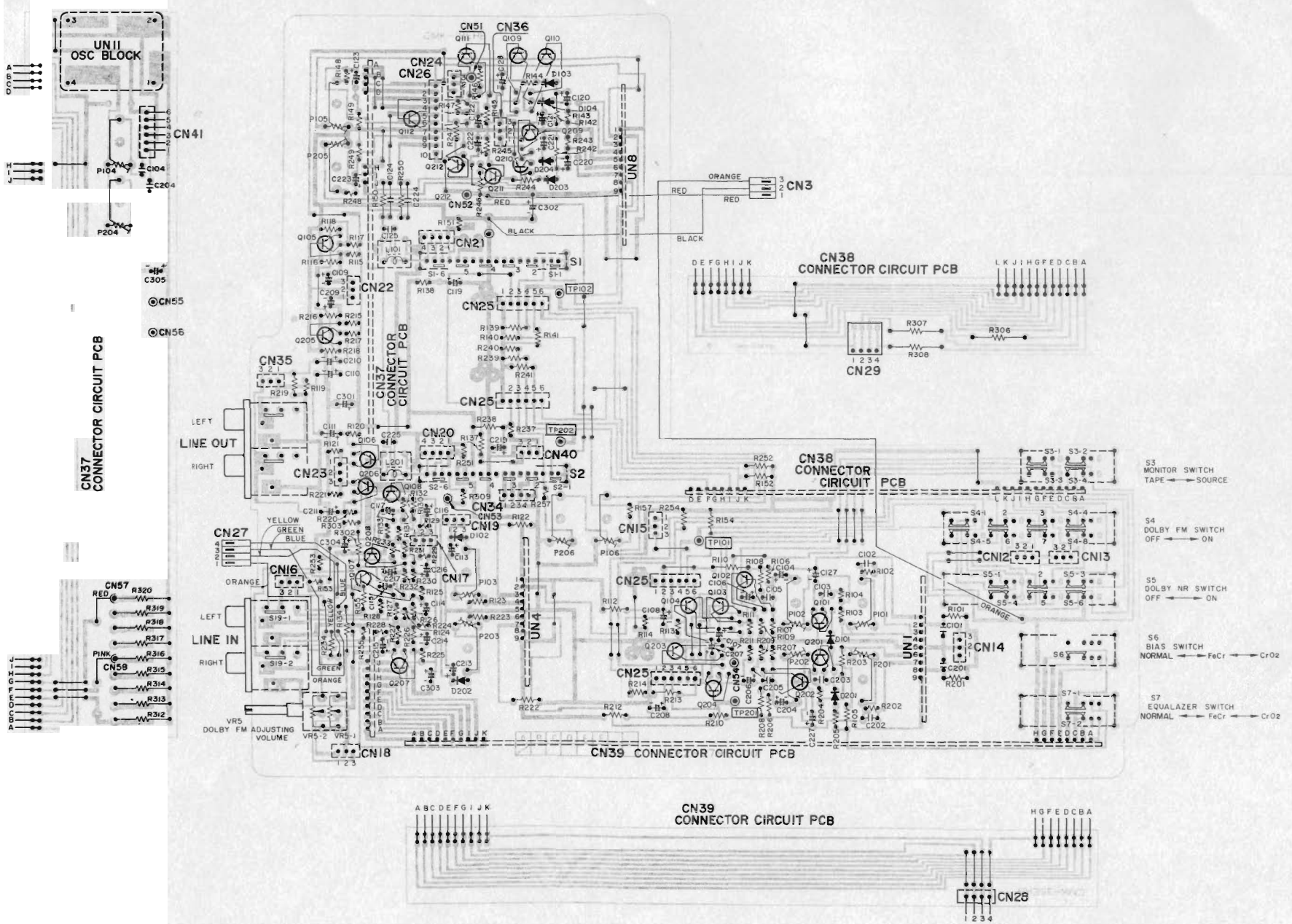

WIRING DIAGRAM

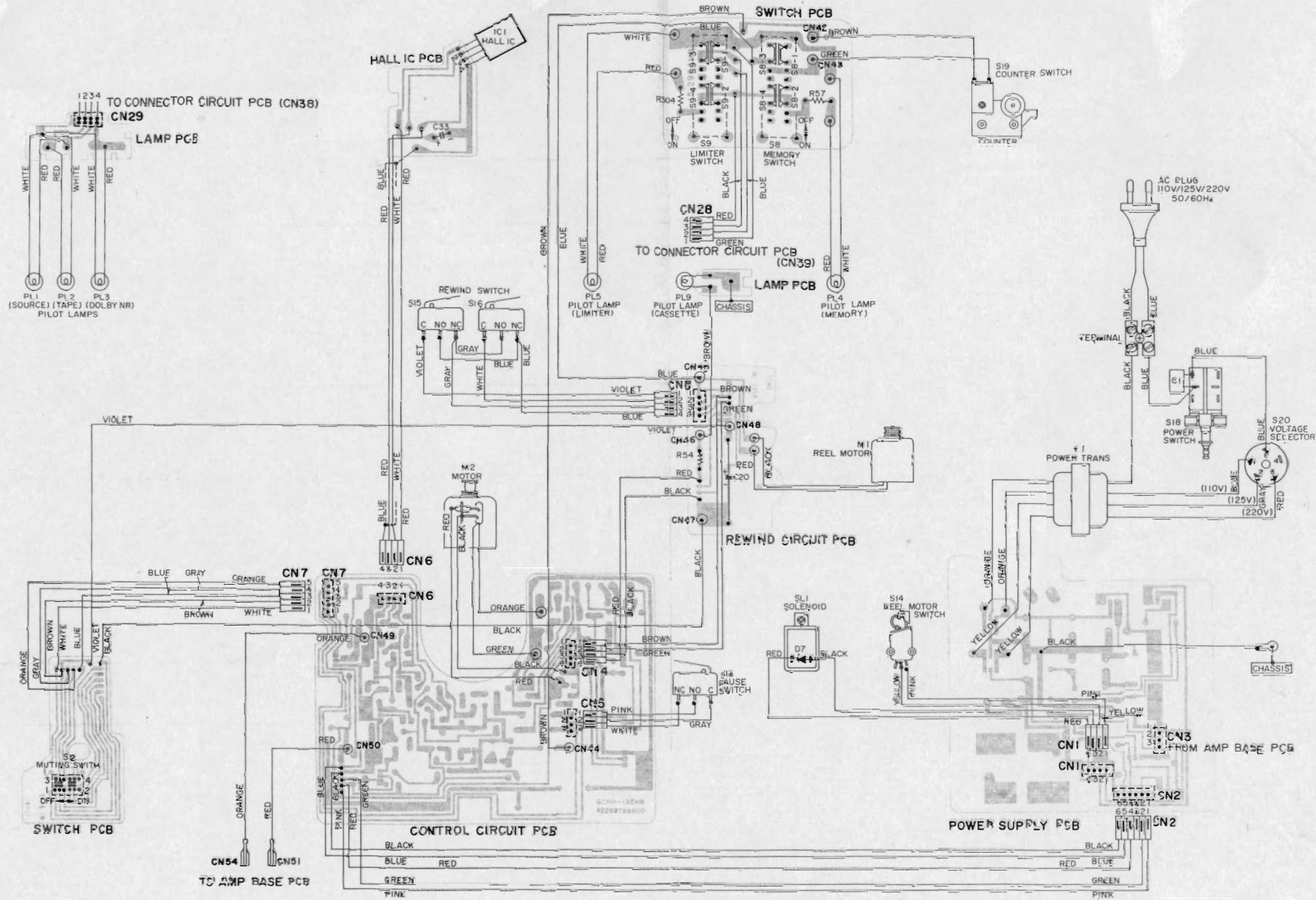

WIRING DIAGRAM

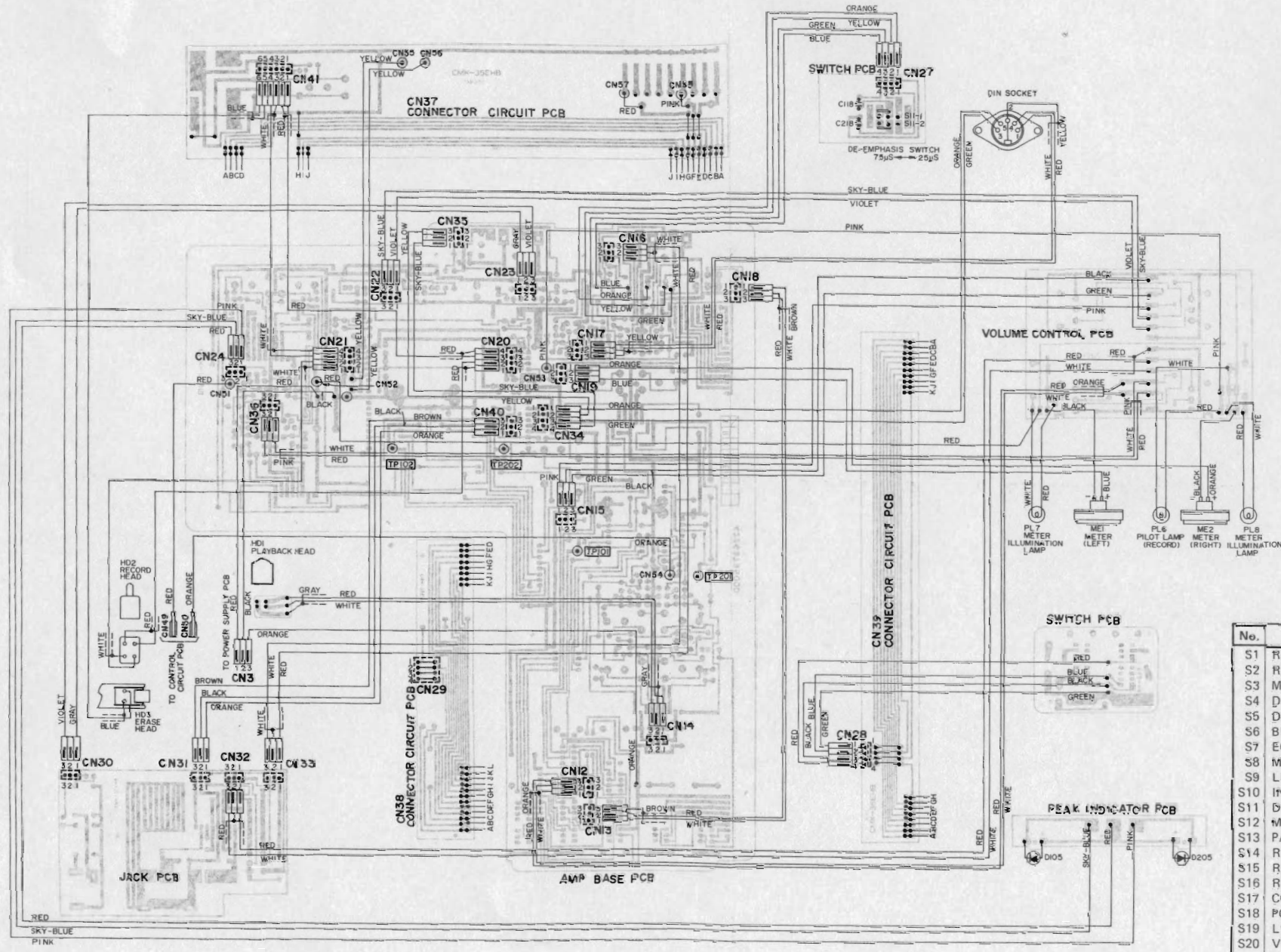

No.	NAME	POSITION
S1	R/P Switch (L Channel)	Playback
S2	R/P Switch (R Channel)	Playback
S3	MONITOR Switch	TAPE
S4	DOLBY FM Switch	OFF
S5	DOLBY NR Switch	OFF
S6	BIAS Switch	NORMAL
S7	EQUALIZER Switch	NORMAL
S8	MEMORY Switch	OFF
S9	LIMITER Switch	OFF
S10	INPUT Selector	LINE
S11	DE-EMPHASIS Switch	75 μ S
S12	MUTING Switch	OFF
S13	PAUSE Switch	OFF
S14	REEL MOTOR Switch	ON
S15	REWIND Switch	OFF
S16	REWIND Switch	OFF
S17	COUNTER Switch	OFF
S18	POWER Switch	ON
S19	LINE/DIN Selector	LINE
S20	Voltage Selector	110V

SCHEMATIC DIAGRAM

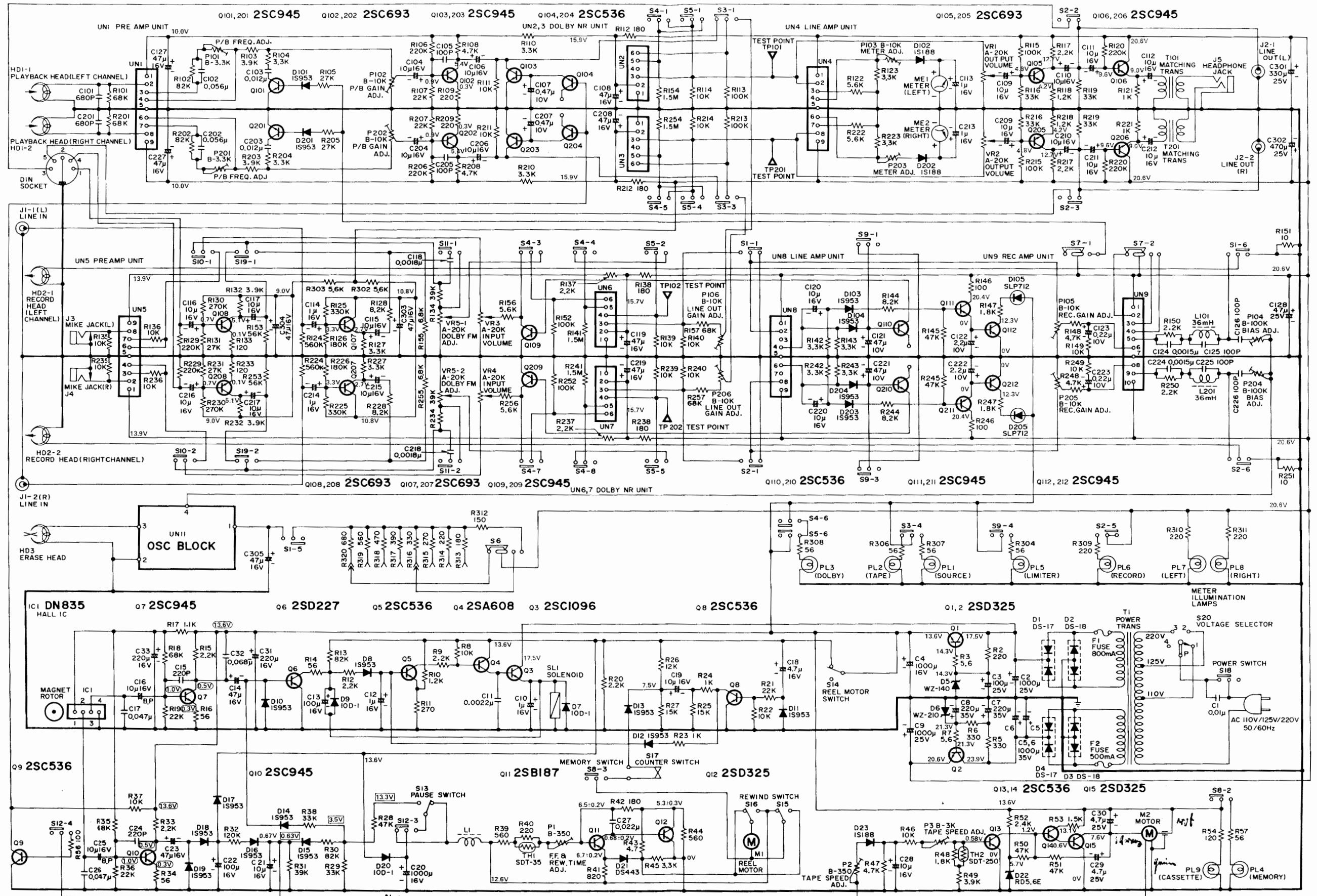

Note:

- Each voltage is measured with V.T.V.M. in the playback mode.
- The voltages described in are measured in the stop mode.
- The voltages described in are measured in the playback mode with the pause button down.

TRANSISTOR LEAD IDENTIFICATION

FRONT VIEW	BOTTOM VIEW	TRANSISTOR	FRONT VIEW	BOTTOM VIEW	TRANSISTOR
		2SC536 2SC693 2SC945 2SD227			2SC1096
		2SB197			
		2SC536			2SD325
		2SA608	TERMINAL NAME		
			B⇒ BASE C⇒ COLLECTOR E⇒ EMITTER		

IC EQUIVALENT CIRCUIT

HALL IC DN835 EQUIVALENT CIRCUIT

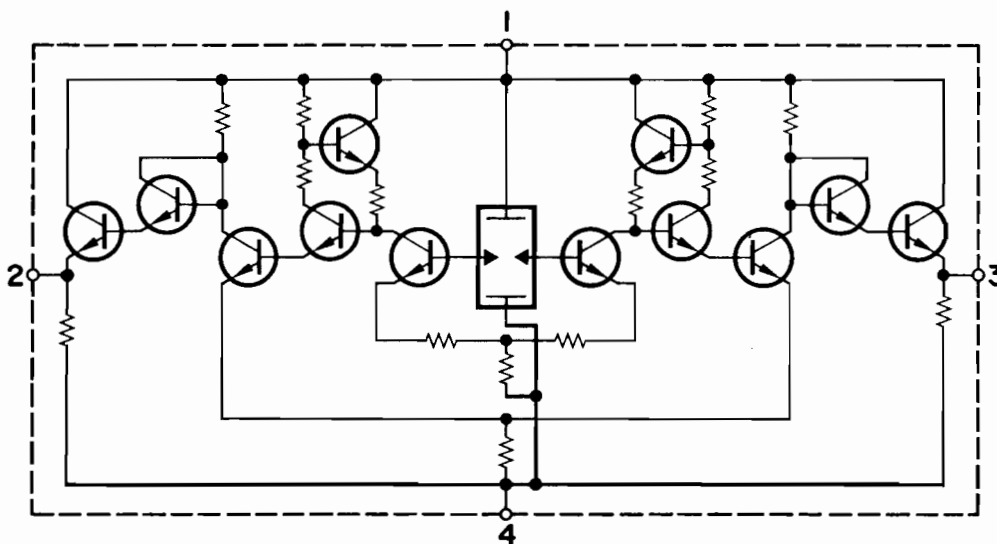

FRONT VIEW

DN835

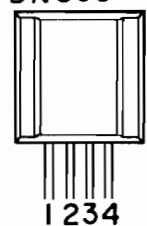

BOTTOM VIEW

